



**2019 Wednesday Evening Series
May-September, 2019
Royal Vancouver Yacht Club
Vancouver, BC**

**ONE DESIGN
SAILING INSTRUCTIONS**

1 RULES

The regatta will be governed by the rules as defined in *The Racing Rules of Sailing*.

2 NOTICES TO COMPETITORS

Notices to competitors will be posted on the official online notice at:
www.royalvan.com/wes.

3 CHANGES TO SAILING INSTRUCTIONS

Any change to the sailing instructions will be posted before 0900 on the day it will take effect, except that any change to the schedule of races will be posted by 2000 on the day before it will take effect.

4 SIGNALS MADE ASHORE

4.1 Signals made ashore will be displayed at RVYC Jericho clubhouse flag mast.

4.2 When flag AP is displayed ashore, '1 minute' is replaced with 'not less than 30 minutes' in the race signal AP.



5 SCHEDULE OF RACES

5.1 Dates of racing:

May Series No.1	May 1	August Series No.1	July 24
May Series No.2	May 8	August Series No.2	July 31
May Series No.3	May 15	August Series No.3	August 7
May Series No.4	May 22	August Series No.4	August 14
June Series No.1	May 29	September Series No.1	August 21
June Series No.2	June 5	September Series No.2	August 28
June Series No.3	June 12	September Series No.3	September 4
June Series No.4	June 19	September Series No.4	September 11
July Series No.1	June 26		
July Series No.2	July 3		
July Series No.3	July 10		
July Series No.4	July 17		

5.2 The first scheduled warning signal on each day of racing will be made at 1800hrs.

6 CLASS FLAGS

Class flags will be:

<u>Class</u>	<u>Flag</u>
M242	M242 Class Flag
Dragon	Dragon Class Flag

7 RACING AREAS

Racing will take place in the Southern portion of English Bay in the vicinity of RVYC Jericho.

8 THE COURSES

The diagrams in Attachment 1 show the courses, including the approximate angles between legs, the order in which marks are to be passed, and the side on which each mark is to be left.

9 MARKS

9.1 Marks 1, 1a, and 2 will be red. Mark S will be an orange and white tetrahedron; Mark F will be a blue and white tetrahedron.



10 AREAS THAT ARE OBSTRUCTIONS

A line beginning at the northwest corner of the RVYC Jericho breakwater, through a series of orange and white can buoys ending with the north end of the most westerly pier at Jericho Sailing Centre, delimits an obstruction. Boats may not pass south of this line.

11 THE START

- 11.1 The starting line will be between a staff displaying an orange flag on the Race Committee Signal Boat, and Mark S.
- 11.2 No fewer than 5 boats must be registered in a class before a start will be given to a class.
- 11.3 Boats whose warning signal has not been made shall avoid the starting area during the starting sequence for other races.
- 11.4 A boat starting later than 4 minutes after her starting signal will be scored Did Not Start without a hearing. This changes rules A4 and A5.

12 CHANGE OF THE NEXT LEG OF THE COURSE

- 12.1 To change the next leg of the course, the race committee will move the original mark (or finishing line) to a new position.

13 THE FINISH

The finishing line will be between Mark F and an orange flag on the Race Committee Signal Boat.

14 PENALTY SYSTEM

- 14.1 For M242 class boats only – The penalty for breaking a rule of Part 2 shall be a One Turn Penalty except that for infringements occurring within the Zone the penalty shall be a Two Turns Penalty. This changes rules 44.1 and 44.2

15 TIME LIMITS

- 15.1 Time limits are as follows:

<u>Class</u>	<u>Time Limit</u>	<u>Mark 1 Time Limit</u>
All classes	60min	30min

If no boat in a particular class has passed Mark 1 within the Mark 1 time limit the race will be abandoned. Failure to meet the target time will not be grounds for redress. This changes rule 62.1(a).

- 15.2 Boats failing to finish within 15 minutes after the first boat sails the course and finishes will be scored Did Not Finish without a hearing. This changes rules 35, A4 and A5.

16 ARBITRATION

- 16.1 RRS Appendix T will apply.
- 16.2 Any arbitration meetings will take place at the first reasonable time after the incident, and prior to a protest hearing at the RVYC Jericho Clubhouse. Arbitration meeting times will be posted on the online notice board.



17 PROTESTS AND REQUESTS FOR REDRESS

- 17.1 Protests and requests for redress or reopening can be filed online by submitting an online protest form via the link provided at www.royalvan.com/wes.
- 17.2 For all classes, the protest time limit is 2359 hrs on the Wednesday evening of the race.
- 17.3 A Hearing Schedule will be posted no later than 1700 hrs on the Friday following the race to inform competitors of hearings in which they are parties or named as witnesses. Hearings will be held at the RVYC Jericho clubhouse in a designated room at the posted time on the Tuesday following the race. The Hearing Schedule link is available in the 'All classes protest area' located at www.royalvan.com/wes

18 SCORING

- 18.1 One race is required to be completed to constitute a series.
- 18.2 When four races in a series have been completed in a particular series a One Design boat's series score will be the total of her race scores excluding her worst score.

When eight or more races have been completed in a particular series a One Design boat's score will be the total of her race scores excluding her two worst scores.
- 18.3 Scoring for each of the five series will be as set out above. Scoring for the overall results of the series will be done similarly. Each series will be scored as one race and the yacht's worst series will be discarded.

19 RACE MANAGEMENT ASSISTANCE

- 19.1 All RVYC registered boats shall provide a crew member to assist in race management activities for one or more race evenings. A sign-up sheet / schedule will be posted online (www.royalvan.com/wes) detailing the date a particular boat is to supply a volunteer. The crew member's responsibilities shall include but are not limited to; performance of Race Committee duties such as timing, recording, signalling; mark setting duties such as positioning marks, and use of a VHF radio for communication. Boats failing to comply with this sailing instruction shall be scored Do Not Exclude ("DNE") for any races held on the evening they are scheduled to provide a crew member, without a hearing, and being scored DNE will not be grounds for redress.
- 19.2 RVYC boats failing to schedule a volunteer time shall be fined \$95 (billed to account) per season.
- 19.3 A boat may apply to the Sailing Director for relief from this requirement for very exceptional reasons.

20 SAFETY REGULATIONS

- 20.1 A boat that retires from a race shall notify the race committee as soon as possible.
- 20.2 All crew participating in race management assistance duties according to SI 17 shall wear adequate personal buoyancy at all times while on the water.



21 EQUIPMENT AND MEASUREMENT CHECKS

A boat or equipment may be inspected at any time for compliance with the class rules and sailing instructions. On the water, a boat can be instructed by a race committee equipment inspector or measurer to proceed immediately to a designated area for inspection.

22 SUPPORT BOATS

Team leaders, coaches and other support personnel shall stay outside areas where boats are racing from the time of the preparatory signal for the first class to start until all boats have finished or retired or the race committee signals a postponement, general recall or abandonment.

23 TRASH DISPOSAL

Boats shall not put trash in the water.

24 RADIO COMMUNICATION

Except in an emergency, a boat shall neither make radio transmissions while racing nor receive radio communications not available to all boats. This restriction also applies to mobile telephones.

25 PRIZES

25.1 Prizes will be given as follows:

Nightly prizes will be awarded according to the following schedule:

- 1st place will be awarded only if 3 or more boats race.
- 2nd place will be awarded only if 5 or more boats race.
- 3rd place will be awarded only if 7 or more boats race.

Overall series prizes will be awarded according to the following schedule:

- 1st place will be awarded only if 5 or more boats register.
- 2nd place will be awarded only if 7 or more boats register.
- 3rd place will be awarded only if 9 or more boats register.

25.2 Prizes for race winners will be awarded at the end of each race night in the RVYC Star & Dragon lounge on the lower level of the Clubhouse following racing.

25.3 Series awards will be presented at the RVYC Prize giving will be held in November.

26 DISCLAIMER OF LIABILITY

Competitors participate in the regatta entirely at their own risk. See rule 4, Decision to Race. The organizing authority will not accept any liability for material damage or personal injury or death sustained in conjunction with or prior to, during, or after the regatta.

27 INSURANCE

Each participating boat shall be insured with valid third-party liability insurance with a minimum cover of \$1 million per event or the equivalent.

28 MEDIA RIGHTS

By participating in the event competitors automatically grant to the organizing authority and its sponsors the right in perpetuity to make, use and show, from time to time at their discretion, any still or motion pictures and live, taped or filmed television and other reproductions of the athlete during the period of the competition without compensation.



ATTACHMENT 1

COURSE DIAGRAMS

Start-1-1a-2-1-1a-Finish

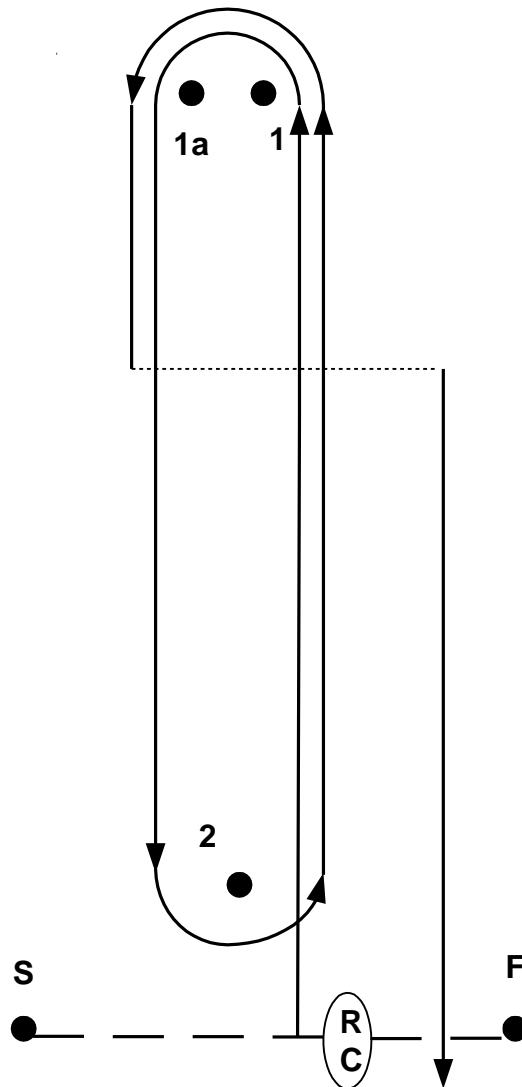

**WHISTLER
BREWING CO.**